



User manual

alphatronics STREAM 2

TABLE OF CONTENTS

1 Introduction	4
1.1 Intended use	4
2. safety instructions	4
3. Scope of delivery	6
4. product in detail	6
5. initial commissioning.....	8
5.1 Connecting the antennas	8
5.1.1 General connection sketch on the router	8
5.1.2 Mounting the outdoor antenna	9
5.1.2 Mounting the router in the vehicle.....	10
5.1.3 Requirements for the assembly site.....	10
5.1.4 Inserting the SIM cards.....	12
5.1.5 Power supply	13
6 Setting up the router	13
6.1 First configuration.....	13
6.1.1 Opening the WEB interface	13
7. Homescreen & interfaces.....	18
7.1 Homescreen	18
7.2 Functional levels	19
7.2.1 Data use.....	19
7.2.2 Speed check.....	20
7.2.3 Available networks.....	20
7.2.4 Own network settings	21
7.2.5 Configuration of the SIM card	22
7.2.6 LAN configuration.....	23
7.2.7 alphatronicsSafe.....	23

7.2.8 Settings.....	24
7.3 Professional Mode / Advanced Settings.....	25
7.3.1 Structure and functions.....	26
8. LED displays.....	28
8.1 Power LED.....	28
8.2 LED Ethernet ports.....	29
8.3 LED connection status.....	29
8.4 LED signal strength.....	30
9 General functions.....	30
9.1 Performing a software update.....	31
9.2 Resetting the unit.....	31
10. Technical data.....	32
10.1 Dimensioning.....	32
10.2 Technical data at a glance.....	33
11. Cleaning.....	34
12. Disposal.....	34

1. INTRODUCTION

Congratulations and thank you for purchasing this product, which is the result of a collaboration between alphatronics, alpine and Teltonika. These operating instructions are intended to assist you in handling and operating the product.

Therefore, please read the instructions for use carefully. Keep the instructions for the entire life of the product and pass them on to subsequent users or owners. Please check the package contents for completeness and ensure that no faulty or damaged parts are included.

1.1 INTENDED USE

This product is a router for receiving LTE signals. The product has 2 SIM card slots. The user can activate one of the two slots via the web interface. An integrated Auto APN function facilitates the automatic setup of all common SIM cards used throughout Europe without additional manual configuration by the user. Furthermore, it is possible to dial into other surrounding WIFI networks with the product.

The set comes with different antenna variants (high-performance outdoor antenna and rod antenna with screws for indoor installation). This product is designed for operation via 12/24 V as well as 230 V with the aid of the supplied power supply unit.

2. SAFETY INSTRUCTIONS

For your own safety and to prevent unnecessary damage to your unit, please read and observe the following safety instructions:

- This product is intended for private, non-commercial use.
- You alone are responsible for how you use your device and for all consequences of its use. Use of the appliance is subject to safety measures to protect users and their environment.
- This product, like all electrical products, does not belong in children's hands!
- This product is not intended to be used by persons (including children) with reduced physical, sensory or mental capabilities, or lack of experience and / or knowledge. Unless they are supervised by a person responsible for their safety or have received instructions from you on how to use the appliance.
- The product must be installed in accordance with the manufacturer's instructions.
- Only use approved accessories! Do not operate the product with incompatible products or accessories.
- Always treat the product and its accessories with care and store it in a clean and dust-free place.
- Do not paint the product or its accessories.

- Do not use the product in a closed environment or in places with poor heat dissipation. Furthermore, do not operate the product in locations with limited ventilation.
- Protect the product from moisture, water, rain, snow or spray and only use the product in dry environments. The product has an IP30 protection rating.
- Never expose the product to high temperatures or extreme cold. Observe the operating temperature specified in the technical data.
- Do not expose the product or its accessories to open flames.
- Do not intentionally drop the product or subject it to extreme shocks.
- Arrange power, antenna and Ethernet cables so that no one could step on them or place other objects on them.
- Do not disassemble the product into its individual parts. The unit does not contain any user-serviceable components. Improper assembly may result in electric shock or malfunction.
- Do not make any modifications to the product, as this will invalidate any warranty claims.
- Never open the unit! Any attempt at repair by unqualified persons may be dangerous and invalidate the warranty claims!
- Do not operate the product outside the specified power limits.
- Make sure that the voltage and rated current of the power source meet the requirements of the unit. Do not connect the unit to an unsuitable power source.
- If your machine or its accessories have been immersed in water, punctured or subjected to a severe fall, do not use it until it has been checked by an authorised service centre.
- This device, like any wireless device, operates on radio signals that cannot guarantee connectivity under all conditions. Therefore, never rely solely on a wireless device for emergency communication or otherwise use the device in situations where the interruption of data connectivity could result in death, personal injury, property damage, loss of data or other losses.

For approval and safety reasons (CE), you must not modify and/or change the product. If you use the product for purposes other than those described above, the product may be damaged. In addition, improper use may cause hazards such as short-circuits, fire, electric shock, etc.

3. SCOPE OF DELIVERY

- LTE/WIFI router
- 12V connection cable with cigarette lighter
- 230V power supply unit
- Outdoor antenna (PUCK) in black ABS housing
- Screw-on LTE rod antenna (2 pieces)
- Screw-on WIFI rod antenna (2 pieces)
- GPS antenna with 3M adhesive pad
- Bluetooth® antenna with magnetic base
- 1.5 m LAN cable
- 2x SIM card adapter + SIM needle
- Additional mounting plugs
- Instruction manual + WIFI passport

4. PRODUCT IN DETAIL

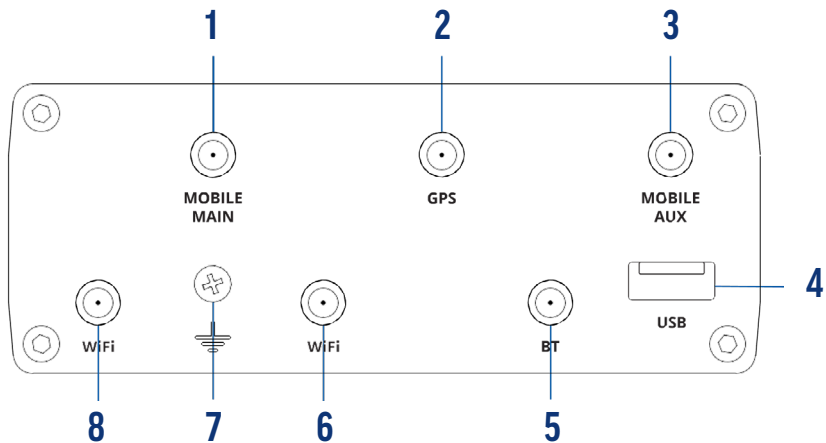

- | | |
|--|---------------------------------|
| 1 Connection LTE antenna (MAIN) | 2 Connection GPS antenna |
| 3 LTE antenna connector (AUX) | 4 USB socket |
| 5 Bluetooth® antenna connector | 6 WIFI antenna connector |
| 7 Screw for earth connection | 8 WIFI antenna connector |



Information: Connectors **1, 2** and **3** are SMA connectors, connectors **5, 6** and **8** are RP-SMA connectors.

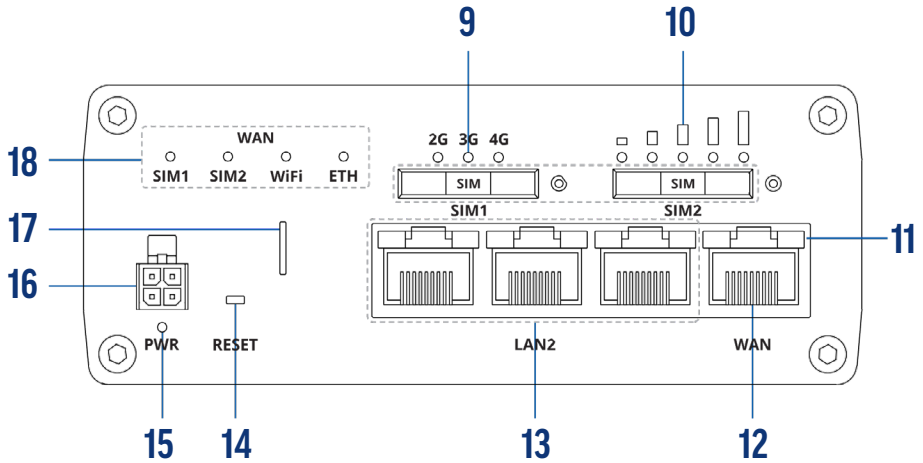

- | | |
|---|--|
| 9 SIM card slot 1 | 10 SIM card slot 2 |
| 11 Status LED (WAN + LAN connection) | 12 WAN connection |
| 13 LAN connection (3 pieces) | 14 RESET button (access only with SIM needle) |
| 15 Status LED (power supply) | 16 Power supply connection (PWR) |
| 17 Holder for SIM needle | 18 Status LEDs (SIM, WIFI, Ethernet (ETH)) |

5. INITIAL COMMISSIONING



Important note!

Check in advance with which of the enclosed antennas the product is to be connected in the vehicle. We generally recommend using the external antenna, as this achieves better reception results, especially in more heavily built (and therefore more highly shielded) vehicles.

5.1 CONNECTING THE ANTENNAS

In order to offer our customers maximum flexibility, several antenna versions are included in the scope of delivery. This allows you to choose individually whether an indoor or outdoor antenna is required, depending on your wishes or the vehicle conditions.

The antennas for GPS and Bluetooth® are optional antennas, they do not necessarily have to be mounted for the standard application. Both antennas are specially designed for extended functions from the submenus. This is the only way to ensure the smooth functioning of the product.

5.1.1 GENERAL CONNECTION SKETCH ON THE ROUTER

1 Connection GPS antenna (Optional)

2 Connection WIFI rod antenna (mandatory!)

3 Connector Bluetooth® antenna (Optional)

Variante A Connection via external antenna

Variante B Connection via indoor antenna

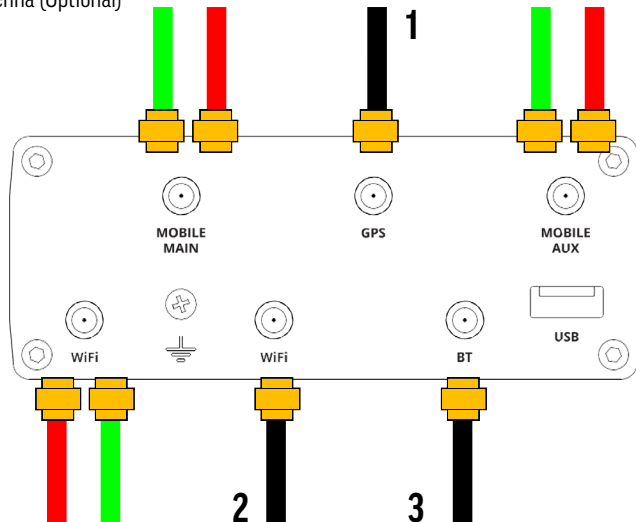

5.1.2 MOUNTING THE OUTDOOR ANTENNA



Important note!

It is imperative that you leave the installation of the external antenna (if you do not have sufficient specialist knowledge) to a specialist company, as otherwise water could penetrate into the interior of the vehicle through the respective installation point! alphonics GmbH does not assume any warranty for this!



Hint! Distance between router and antenna

When mounting the outdoor antenna, pay attention to the distance to the router. The preconfigured connection cable of the antenna has a maximum length of 3.0 m. Therefore, only mount the router within this radius.

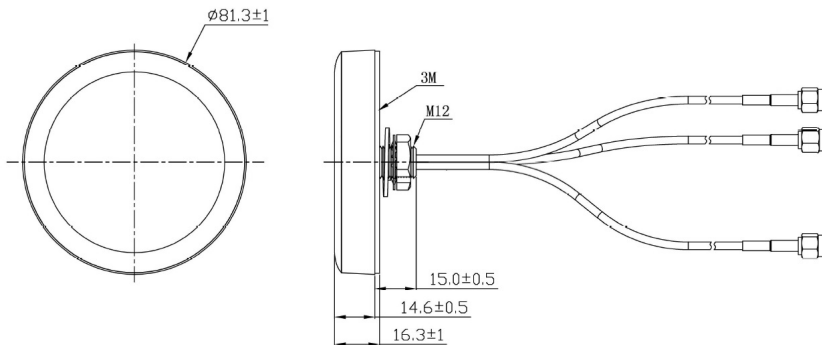

Structure of the outdoor antenna:

The outdoor antenna has a cable feed-through in the centre (under the product).

Proceed as follows for assembly:

1. Loosen / dismantle the nut and the two washers attached to the antenna.
2. Define an agreed mounting location on the roof of the vehicle and clean it thoroughly.
3. Now drill a hole with a diameter of 12 mm. **Important!** Take special care here that there are no extensions underneath the roof that could be damaged.
4. Now clean and degrease the installation site again and deburr any drill edges that may have formed.
5. Carefully guide the 3 cable strands of the antenna through the opening into the interior of the vehicle. We advise you to carefully guide them through the opening one after the other.



Recommendation for tightness: To ensure 100 % tightness, we advise the use of e.g. Sikaflex® 292 or an equivalent PU structural adhesive. Apply an appropriate layer of adhesive here according to the illustration (blue marked circle) and then carefully press the antenna on.



6. Now secure the antenna again from below with the corresponding washers and nut. (Sequence: red sealing washer -> silver toothed washer -> assembly nut) and then hand-tighten the nut.
7. Especially in connection with the glue and the tightening of the antenna, watch out for further glue or silicone leaking out and remove it immediately before it sets.
8. Now the cables can be connected to the router according to the marking (on the cable - above the plugs).
9. For optimal functioning of the router, the antennas for GPS and WIFI (inside the vehicle) must also be connected here (see connection diagram under point 5.1.1).

Mounting positions:

GPS antenna

It is best to mount the GPS antenna in a place in the vehicle where it can receive a good signal from outside. Any technical cabinets are not suitable here, as they shield the signal too much. The installation of the GPS antenna is optional! It is not required for basic applications, but only for special applications.

WIFI antenna

Always mount both WIFI antennas on the router. Only by connecting both antennas can the router work properly. Either both rod antennas are mounted or 1 rod antenna + connection cable of the external antenna.

Bluetooth® antenna

It is best to mount the Bluetooth® antenna in a place in the vehicle where it can receive a good signal from outside. Any technical cabinets are not suitable here, as they shield the signal too much. The installation of the GPS antenna is optional! It is not required for basic applications, but only for special applications.

5.1.3 Requirements for the assembly site



Important safety instructions for choosing the installation location!

- Do not install near any air conditioning or heat sources such as radiators, heat registers, stoves, or other apparatus (including amplifiers) that produce heat. Refer to the operating & ambient temperature specifications.
- Make sure that the unit is adequately ventilated at the installation site and do not install it in completely closed cabinets or boxes to avoid overheating due to insufficient heat dissipation.
- Do not operate the product in a very dusty environment. Dust particles and other foreign bodies may otherwise cause damage to the product.
- Protect the power cable from being walked on or pinched particularly at plugs, convenience receptacles, and the point where they exit from the unit.
- When using with a 230 V power supply, make sure that the socket is close to the appliance and that it is easily accessible.
- Operation outside the permissible range can significantly shorten the life of the unit.

Space requirement:

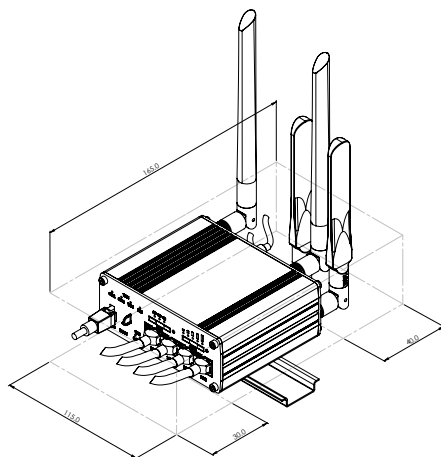



Professional tip - Transferring data to the WIFI passport

The WIFI SSID and the WIFI password for the initial installation are located on the back of the device. Since the router is mounted / screwed into the vehicle, we advise transferring or photographing the corresponding data on the WIFI passport before mounting the router.



Information - Heating of the product

A certain warming of the product during use (especially over a longer period of time) is normal.

5.1.4 Inserting the SIM cards

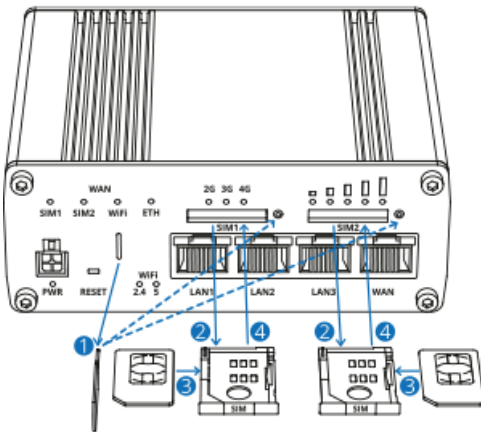

Information SIM card size (Overview):

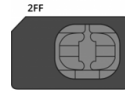

2FF = Mini-SIM

3FF = Micro-SIM

4FF = Nano-SIM

1. Press the button on the SIM holder (to the right of the SIM slot) with the SIM needle.
2. Carefully pull out the SIM holder with your fingers.
3. Now insert your SIM card into the SIM holder with the contacts facing upwards. If necessary, use the enclosed SIM card adapters. The product is compatible with cards in mini-SIM format (2FF).
4. Carefully insert the SIM holder back into the router. Make sure that nothing is jammed in the slot and do not use force.

5.1.5 Power supply

This product is designed for mobile use in a vehicle (12V) or truck (24V) as well as for operation at home via a 230 V power supply unit. Only connect the product with the enclosed accessories. The exact specifications for this can be found in the technical data under 10.2.

6. SETTING UP THE ROUTER

6.1 First configuration

After the product has been connected according to chapter 5, you can start with the initial setup and commissioning of the unit.

When the power supply is active, the unit starts automatically and initialises. This is indicated by the green power LED below the power supply.

6.1.1 Opening the WEB interface



Recommendation: We recommend setting up the router via a smartphone, tablet or laptop because it is easier to enter the data. In the following, the setup is described using the example of a smartphone.

1. Now connect your smartphone to the router, select the corresponding network SSID in the WIFI settings of the end device (network name - always begins with RUTxxx_xxxx).

The respective data (SSID & password) are on the back of the router. Ideally, these have been transferred to the corresponding WIFI passport or photographed as described in the professional tip under 5.1.3.



Information: Each alphantronics Stream Router is delivered with an individually generated SSID and password. This is to ensure the protection of the product and the network against misuse.

2. Wait until the smartphone has successfully paired with the router.

Since the router has not yet been configured, the smartphone may display „Low security“ or „No network connection“. You can ignore this message for the time being. Make sure that the smartphone does not automatically switch to another network.

3. Now open the browser of your smartphone (e.g. Safari or Google Chrome) and enter **192.168.1.1** in the search bar. Confirm the selection with Enter.

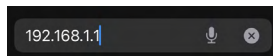

Alternatively, you can also scan the QR on the front of the router. This will automatically open the corresponding browser page on your smartphone.

The following login screen will now appear on the screen.

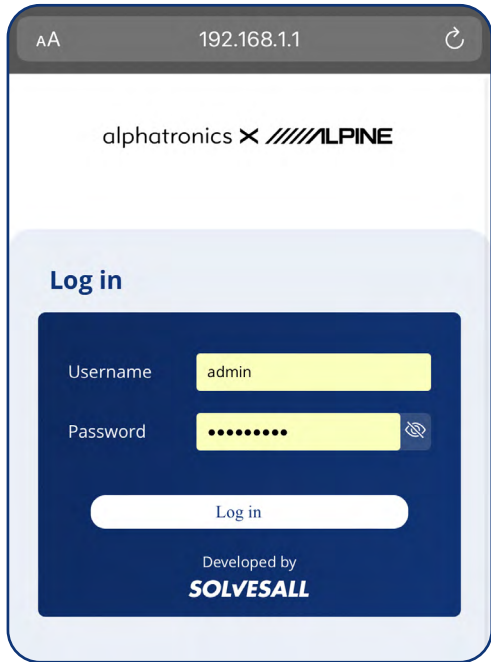

4. Now enter the following data here:

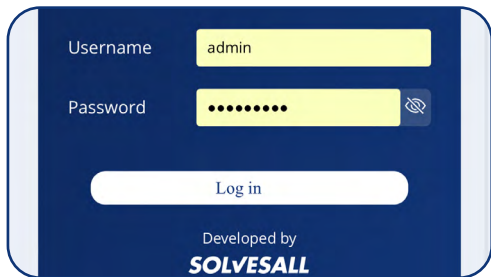

Information - Default Password

The required data is also on the back of the router. This data is only required **for the initial setup**, the password must be replaced with a new one in the next step for security reasons.

5. Selection of the language

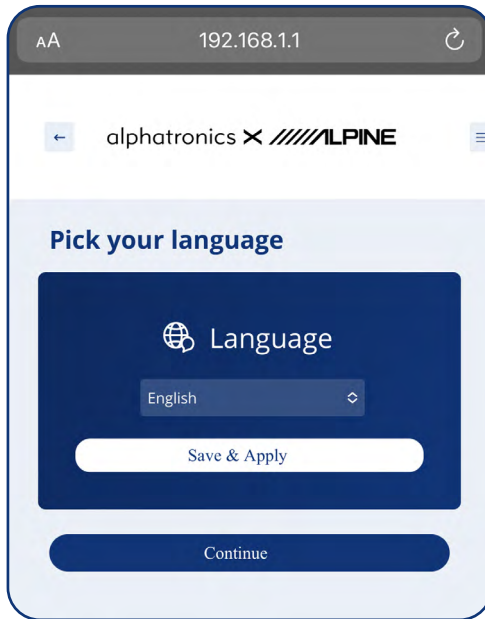

Select the desired national language here.

The following languages are available at the beginning: German, English, French

We will systematically expand this with later software updates.

Confirm the language selection with the „Save & Apply“ button. The corresponding language package is unpacked and installed in the background. As soon as this is complete, you can select the next configuration item via the „Next“ button.

6. Welcome screen

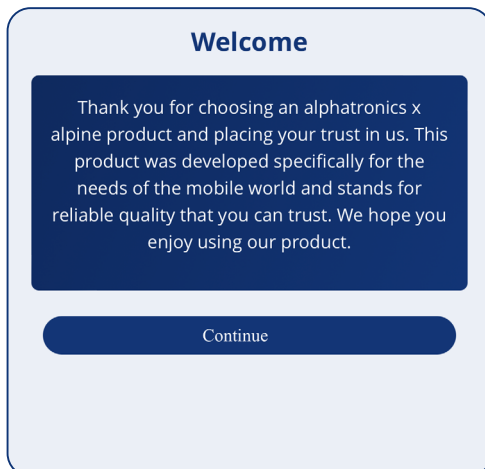

7. Confirmation of the end user licence agreement



Read the End User Licence Agreement completely. At the end of the text there is a button with „accept“. By pressing this, you agree to the EULA (End User Licence Agreement). The product cannot be operated without the corresponding consent.

8. Assigning a new password

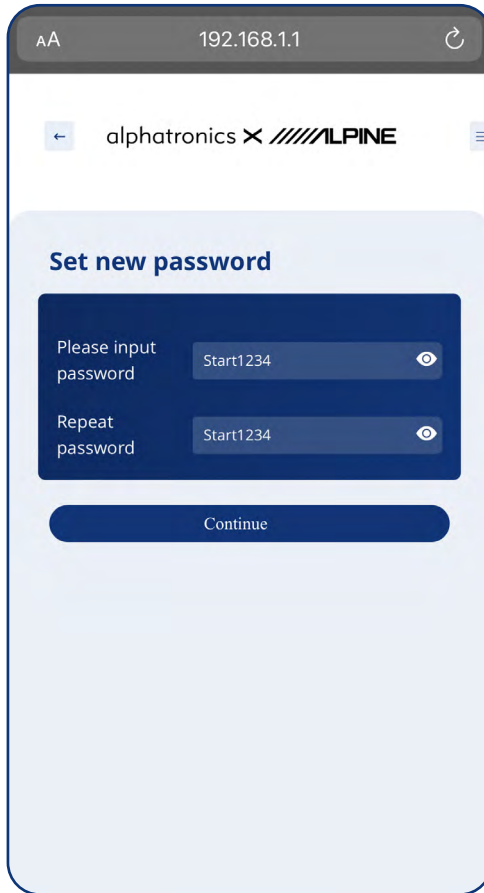

The screenshot shows a mobile browser interface for setting a new password. The address bar displays '192.168.1.1'. The page title is 'alphatronics X //ALPINE'. The main heading is 'Set new password'. There are two input fields: 'Please input password' and 'Repeat password', both containing the text 'Start1234'. Each field has an eye icon to toggle visibility. A 'Continue' button is located below the input fields.

To ensure maximum security for you and your network, the password **must** be replaced with a new one during the initial installation.

Defaults for the new password:

- At least 8 digits
- Upper case as well as lower case letter must be included
- It must contain at least one number

Notice!

Through the web interface, password suggestions from Apple or Android can also be selected here. In addition, the new password can also be saved in the key ring of the device.

9. The initial installation is now successfully completed.

7. HOMESCREEN & INTERFACES

During the joint development between alphatronics and alpine, it was always important to us to make the interface simple, intuitive and understandable for all user groups. The incentive here was to create an ideal balance between an easy-to-use interface and yet all functions.

7.1 Home screen

The homescreen is the central hub of the interface. All important information can be viewed or selected directly here.

Back button to exit the corresponding submenus.

Activation / deactivation of the SIM card: **Important!** Only one SIM card can be used at a time.

External WIFI network: Indicates whether the router is connected to an external network.

Selecting the **important settings and functions.**

Opening the extra mask for **additional functions of Teltonika** (professional mode)

Load Balancing: If this function is activated, the router automatically switches to the mobile network in the event of a poor WIFI connection and obtains data packets from both reception sources.

Hint! This can lead to a higher load on the data limit!

7.2 Functional levels

7.2.1 Data use

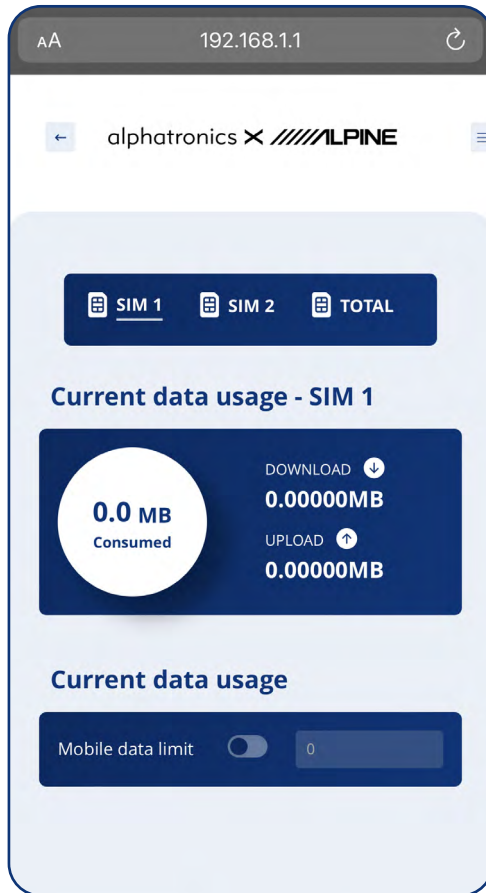

In this level, the data consumption of the respective SIM card can be determined and displayed.

Here you have the option of displaying this individually or in total for both SIM cards together.

In addition, it is possible to set a data limit for the corresponding SIM card.

As soon as this is reached, the router does not allow any further data retrieval. This is a helpful function, especially with prepaid cards or when using the product abroad, to avoid additional costs.

7.2.2 Speed check

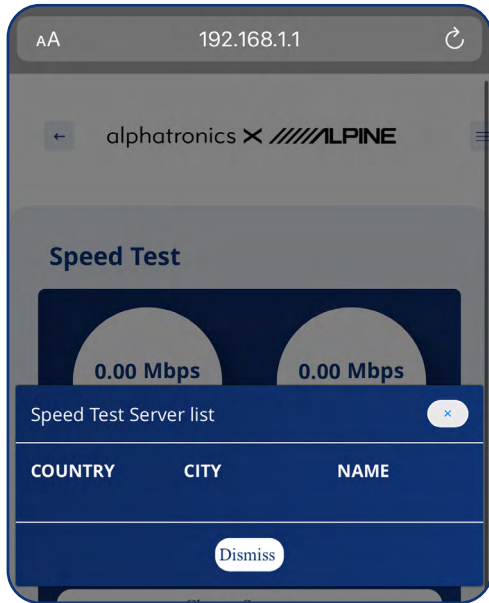

Sometimes it can happen that the speed is not sufficient and corresponding data is retrieved slowly or not at all. Depending on the location, it can be helpful to carry out a speed test.

To do this, select the desired server or server location and carry out an appropriate test.

Notice!

For the speed test, data is retrieved via the SIM card. This leads to a correspondingly higher data consumption, so this should only be carried out if sufficient data volume is available.

7.2.3 Available networks

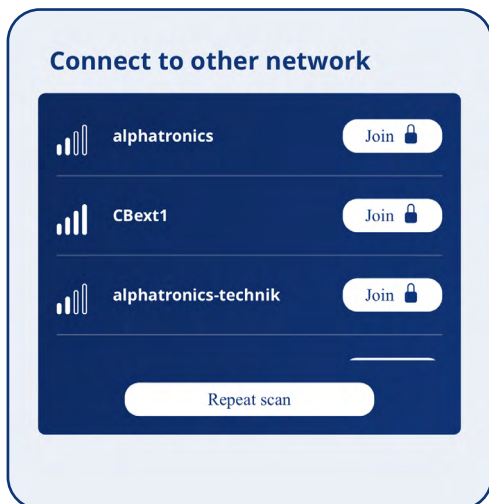

This function level allows you to connect the router to existing WIFI networks in the vicinity.

This is a useful function, especially on parking lots or in public WIFI networks, to reduce data consumption via the SIM card.

To do this, select the desired network accordingly via the „Connect“ button.

If the network did not appear in the search, you can repeat the network scan via „Repeat search“.

7.2.4 Own network settings

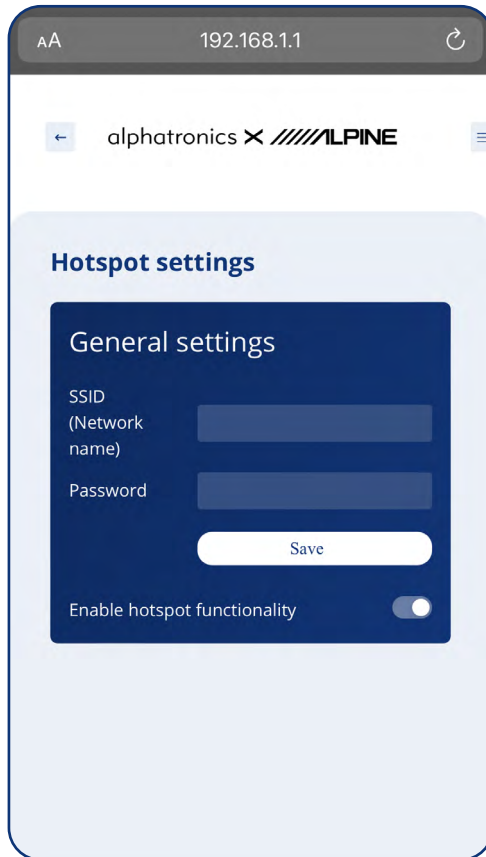

In this level, the information on one's own network can be viewed.

Here you can change the network name (display name of your network) and the corresponding password.

Here, too, we advise you to transfer any changes to the corresponding data to the WIFI passport. This is a helpful tool especially in situations where new users or devices are to be registered in the WIFI.

7.2.5 Configuration of the SIM card

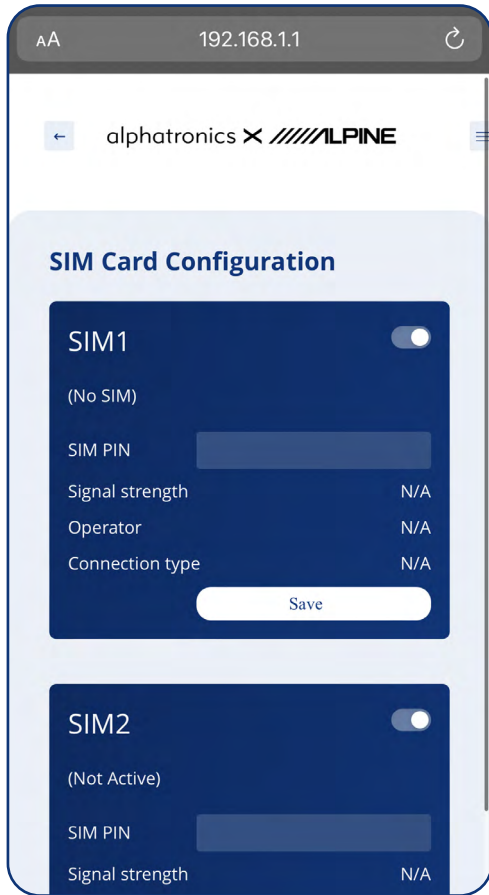

The most important information about the SIM cards can be viewed here. In addition, the SIM PIN of the corresponding card can be stored here.

This is especially important if the card has active SIM protection. Otherwise the device cannot access the data interface or SIM card.

In addition, the operator as well as the connection type and the current signal strength are also displayed here.

What is Auto APN?

APN is short for Access Point Name and means something like access point name. The correct APN settings are required so that you can surf the Internet from your device when you are on the move. These are already stored for the most common providers and thus make it easier to set up the device.

7.2.6 LAN configuration

IP address 192.168.1.1

Netmask 255.255.255.0

DHCP configuration

Start 100

Limit 150

Lease time 12 Hours

Start IP address 192.168.1.100

End IP address 192.168.1.249

Save

In this level, the most important LAN configurations can be viewed.

7.2.7 alpatronics Safe

alpatronicsSafe

Please make sure that the setting made do not interact with other settings, e.g. of the VPN or other services blocked.

 Create a blacklist of websites that should not be opened via the router connection

Hostname

Add hostname

This section contains no values yet

Security is an important issue, especially in relation to the Internet. We also want to make our contribution to a safe use of the internet.

alpatronics Safe is a simple yet effective way to block certain websites and their access.

Activate the function via the slider. As soon as this is done, all the websites stored here can no longer be accessed via any device (in the WIFI network - which are connected to the alpatronics stream).

This is a helpful function, especially for children, to make surfing the internet safer.

7.2.8 Settings

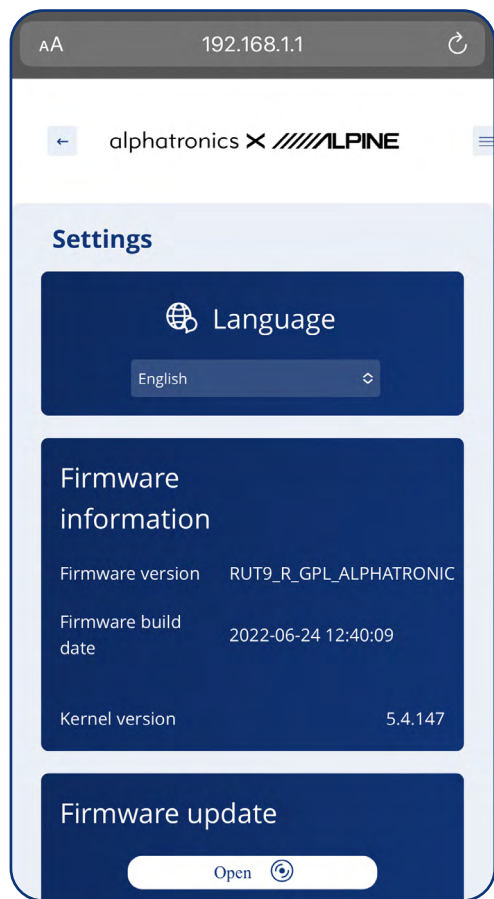

In this level, the most important settings of the unit can be made.

Language

Change the currently selected language to another.

Firmware information

Here you can view the current firmware version of the software and its date.

Firmware updates

New updates provided by us can be imported into the product via this menu item. It was particularly important to us that this is possible via smartphone, tablet and laptop.

7.3 Professional Mode / Advanced Settings

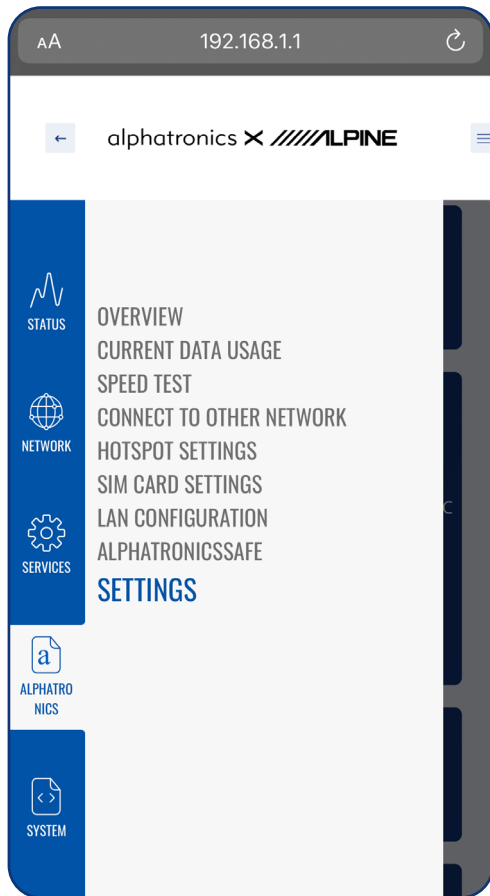

The three dashes at the top right of the logo can be used to open the advanced settings of the unit (professional mode).

When developing the interface, we basically tried to control 90% of the functions via our interface.

However, depending on the application, additional functions may be required.

For this purpose, we have additionally integrated the Teltonika interface into our router. As soon as you select the 3 stitches, the following display appears.

7.3.1 Structure and functions

Since the interface is the original variant of Teltonika, we have linked all chapters to the Teltonika WIKI accordingly.

In order to be able to open them directly, we recommend that you also download the operating instructions as a digital version from our homepage in the support area.

Alternatively, you can also scan the QR code with your smartphone. -> This is linked to the Teltonika overview page.

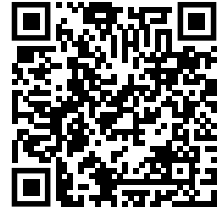

Teltonika has an excellent and extensively maintained WIKI for this purpose, in which all parameters and functions are explained in detail. The WIKI is maintained in several languages and updated regularly.

STATUS

[Overview](#)

[Routes](#)

[Mobile Usage](#)

[System](#)

[Services](#)

[Logs](#)

[Network](#)

[Realtime Data](#)

NETWORK

[Mobile](#)

[Wireless](#)

[Routing](#)

[Interfaces](#)

[Failover](#)

[DNS](#)

[WAN](#)

[Firewall](#)

[LAN](#)

[VLAN](#)

SYSTEM

[Administration](#)

[Backup](#)

[Profiles](#)

[System Users](#)

[CLI](#)

[Reboot](#)

[Setup Wizard](#)

[Custom Scripts](#)

[Firmware](#)

[Speed Test](#)

SERVICES[Package Manager](#)[Cloud Solutions](#)[VPN](#)[Mobile Utilities](#)[Email Relay](#)[Auto Reboot](#)[Port Mirroring](#)[OPC UA](#)[Modbus](#)[Serial Utilities](#)[DNP3](#)[Input/Output](#)[GPS](#)[IGMP Proxy](#)[Bluetooth](#)[Data to Server](#)[Events Reporting](#)[Traffic Logging](#)[USB Tools](#)[Hotspot](#)[Hotspot 2.0](#)[Web Filter](#)[Dynamic DNS](#)[Traffic Shaping](#)[MQTT](#)[SNMP](#)[TR-069](#)[NTP](#)[UPNP](#)[Wake on LAN](#)[VRRP](#)[SSHFS](#)

8. LED INDICATORS

For a visual check of the function or in case of problems, the product has several LEDs that indicate the respective status of the function.

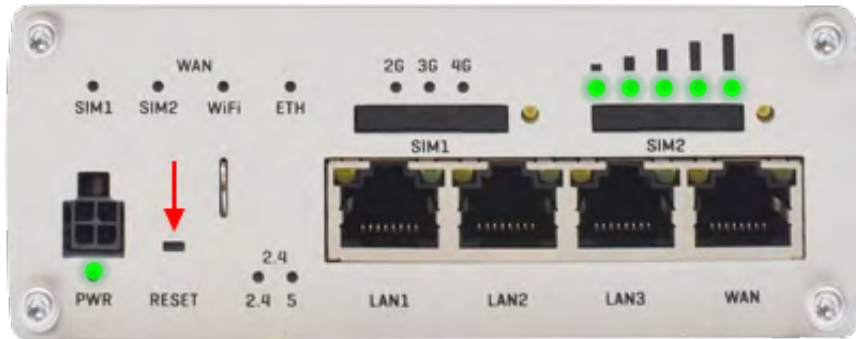

8.1 Power LED

The POWER LED (PWR for short) is located in the lower left corner.

LED switched on:

The router is switched on and ready for operation

LED switched off:

The router is not switched on or is not supplied with power

8.2 LED Ethernet ports

Here, one LED each is located directly above the corresponding Ethernet port.

LED switched on:

Port is active - operation with 10/100 Mbit/s

LED switched off:

No connection was established

LED flashes:

Active connection / activity on the port (e.g. retrieval of data)

LEDs light up and go out one after the other from right to left:

The router is in the bootloader menu state

**Information:**

The bootloader menu is a special router state via which upgrades or restores can be carried out. Please refer to point 9.1.

8.3 LED connection status

The connection status LED is located at the top right above the SIM slots. Among other things, the LED shows the current connection status and network type of the router.

The LED lights up alternately green and red:

No SIM card recognised or incorrect PIN entry

The LED lights up alternately green, red and orange:

Connection to GSM

LED flashes red:

2G connected, no data session established

LED flashes orange:

3G connected, no data session established

LED flashes green:

4G connected, no data session established

The LED lights up red and flashes rapidly while data is being transferred:

Connected 2G network with active data session

The LED lights up orange and flashes rapidly while data is being transferred:

Connected 3G network with active data session

The LED lights up green and flashes rapidly while data is being transferred:

Connected 4G network with active data session

8.4 LED signal strength

The LED for the signal strength is located in the lower right corner, to the right of the LED display for the connection status. Each lit LED represents a different value of the current signal strength of the router in RSSI.

Number of lit LEDs corresponds to a signal strength of

0	≤ -111 dBm
1	-110 dBm to -97 dBm
2	-96 dBm to -82 dBm
3	-81 dBm to -67 dBm
4	-66 dBm to -52 dBm
5	≥ -51 dBm

9. GENERAL FUNCTIONS

9.1 Performing a software update

We are constantly developing and optimising this product. Therefore, we will continue to offer function updates and bug fixes in the future. You can find these firmware updates on our homepage in the Support category and download them from there. Installing the software is very easy and can be done via smartphone, tablet or PC / laptop.

1. Download the corresponding firmware package from our homepage to your mobile device.
2. Open the web interface via 192.168.1.1 and log in here with your user data.
3. Now open the function level Settings and go to the item Firmware Update.
4. Select the appropriate update from your file explorer.
5. The unit loads the firmware into the router and checks it for compatibility.
6. Now you can execute the update by clicking on Start. This takes about 3-5 minutes.

Your end device will lose the connection to the router for a short time because it restarts several times during the update. After about 5 minutes, you can select the network again in the WIFI settings.

9.2 Resetting the unit

The reset button is located on the back of the unit and has 2 functions:

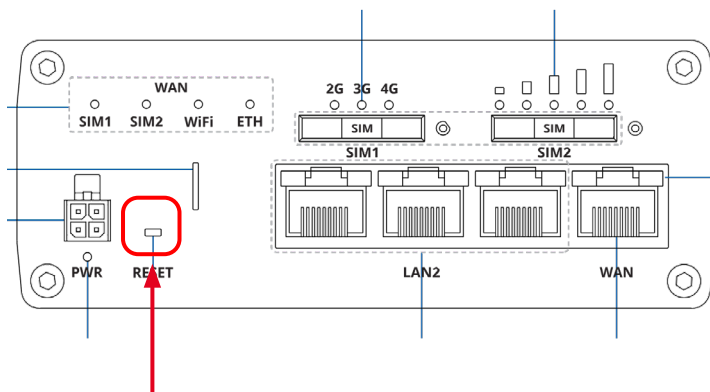

Function 1 - Restarting the unit

When the reset button is pressed for up to 4 seconds, the unit restarts. The start of the restart is indicated by all 5 signal strength LEDs flashing together with the green connection status LED.

Function 2 - Factory reset

When the reset button is pressed for at least 5 seconds (by default), the unit performs a factory reset and then restarts. Signal strength LEDs indicate the elapsed time while the reset button is held down. When all 5 LEDs light up, this indicates that 5 seconds have passed and the reset button can be released.

The start of the factory reset is indicated by all 5 LEDs flashing together with a red connection status LED.



Reset information

The default value for the key hold time (5 seconds) can be changed in professional mode (3 stitches) under System -> Administration -> General.

10. TECHNICAL DATA

10.1 Dimensioning

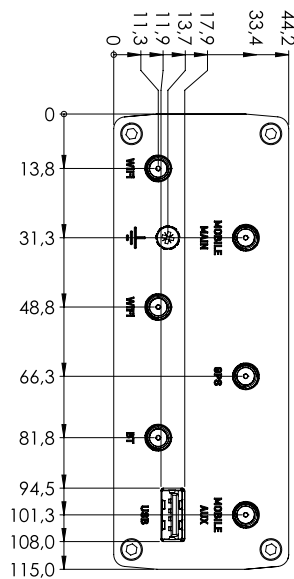
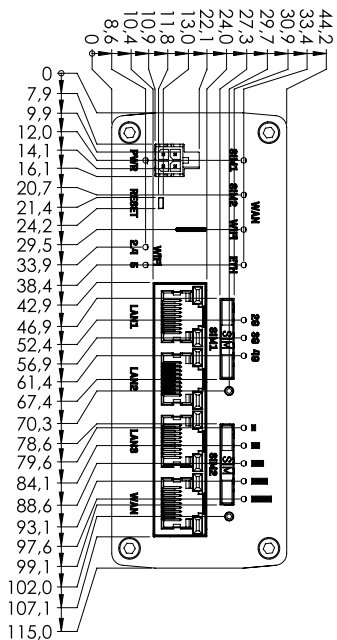
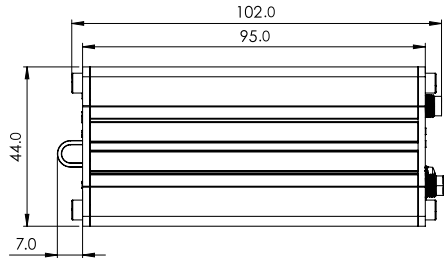
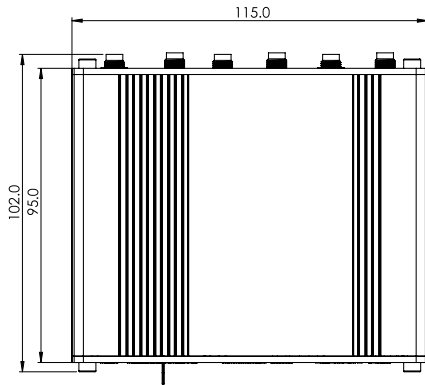

10.2 Technical data at a glance

General		
Article name	alphatronics Stream 2	
Item number	990783	
Dimensions (W x D x H)	115 x 95 x 45 mm	
Weight	460 gram	
Housing material	Aluminium, plastic	
Protection class	IP30	
Operating temperature	-40° C to +75° C	
Operating humidity	10 % to 90 % (non-condensing)	
Connections	2 x SMA (socket) for LTE 2 x RP-SMA (socket) for WLAN 1x SMA (socket) for GPS 1x SMA (socket) for Bluetooth*	3x LAN socket + 1x WAN socket 1x USB socket (USB 2.0) 1x 4-PIN power connector (DC) 2x SIM slot (SIM1 & SIM2)
Mobile radio		
Supported regions	Europe, Middle East, Africa, APAC ¹ , Brazil, Malaysia, Australia	
Supported mobile phone bands	4G (LTE-FDD): B1, B3, B5, B7, B8, B20, B28, B32 ² 4G (LTE-TDD): B38, B40, B41 3G: B1, B3, B5, B8	
Number of SIM slots	2x (format 2FF)	
Mobile communication standards	4G (LTE): CAT 6 up to 300 Mbit/s 3G: up to 42 Mbit/s	
Auto APN (automatic configuration)	Available for the most common operators	
WIFI		
WIFI Standards	2.4 GHz (IEEE 802.11b/g/n) 5.0 GHz (IEEE 802.11ac/n/a)	
WIFI modes	AP mode (Access Point) / Station (STA)	
Number of WIFI participants	max. 100 pieces	
Encryption	WPA3-EAP, WPA3-SAE, WPA2-Enterprise-PEAP, WPA2-PSK, WEP; AES-CCMP, TKIP, Auto Cipher, Client Separation	
Power supply		
Input voltage range	9 – 50 V	
Power consumption	max. 16W	

¹Excluding Japan and CMCC

²LTE-FDD B29 and B32 only support RX

11. CLEANING



Important safety note!

Always take the product out of operation and disconnect it from the power supply before carrying out any cleaning work. When cleaning, make sure that no moisture gets into the product.

Use a soft, lint-free cloth for cleaning. Under no circumstances use liquid, gaseous or highly flammable cleaning agents such as sprays, abrasives, polishes or alcohol. During cleaning, make sure that no moisture gets inside the product. Especially refrain from spraying cleaning liquids on the product. Wipe gently over the surfaces of the enclosure. Always take care not to accidentally scratch the surfaces.

12. DISPOSAL



All products marked with this symbol are e-waste and electrical appliances (WEEE according to EU Directive 2012/19/EU) and must not be mixed with unsorted household waste. Instead, protect your fellow human beings and the environment by taking your equipment for disposal to a designated collection point set up by the government or a local authority for the recycling of e-waste and electrical equipment. A proper Disposal and recycling help to avoid negative effects on the health of the environment and people. Please contact the installer or local authorities for information on the location and terms and conditions of such collection points.

To protect against transport damage, the product is delivered in packaging made of recyclable materials. Dispose of this packaging by type in the collection containers provided. For environmentally friendly disposal of the product, ask your local waste disposal company or your municipal administration.

Disclaimer

alphatronics GmbH does not accept any liability or warranty for damage resulting from improper installation or assembly as well as improper use of the product or failure to observe the safety instructions.

Improvements and changes to these operating instructions - due to printing errors, inaccuracy of the information provided or improvements to the product - may be made by alphatronics at any time and without prior notice. Such changes will be incorporated in newer editions of these operating instructions or in the online version. All images are for illustrative purposes only and do not necessarily represent the actual device 100% accurately.

Copyright

These operating instructions are protected by copyright. Any reproduction or reprinting, even of extracts, as well as the reproduction of illustrations, even in modified form, is only permitted with the written consent of the manufacturer.

Notes on the guarantee

The warranty period begins with the purchase of the unit. Please provide proof of this date with the purchase receipt. Please keep these documents in a safe place. Our guarantee is based on our guarantee conditions valid at the time of purchase. The guarantee period for this product is 3 years.

Legal notice

Apple®, iPhone® and iPad® are trademarks, App Store is a service mark of Apple Inc, registered in the U.S. and other countries. Google® and Android® are trademarks of Google, Inc. Other names or designations mentioned may be the trademarks or registered trademarks of the be the respective owner.

Licence Statement / GPL Code Statement

This product contains software code developed by third parties, including software code that is GNU General Public License Version 2 ("GPLv2").

Simplified declaration of conformity according to RED Directive

Hereby, alpatronics GmbH declares that the described type of radio equipment complies with Directive 2014/53/EU and the other directives applicable to the product. The full text of the EU declaration of conformity is available at the following internet address:

<https://alpatronics.de/de/support/konformitaetserklaerung.83/>

Additional legal information:

Frequency ranges:

Mobile radio: 699 – 868 MHz / 1850 – 2690 MHz
 WIFI: 2400 – 2500 GHz
 GNSS 1575,42 – 1602 MHz

Maximum transmitting power:

GSM:	33 dBm	LTE:	23 dBm
WCDMA:	24 dBm	WIFI:	20 dBm

alpatronics GmbH
Breitengraserstraße 6
90482 Nürnberg

Tel. +49 (0) 911 21 65 54-0
Fax +49 (0) 911 21 65 54-65

alpatronics-Service:
Tel. +49 (0) 911 21 65 54-45
E-Mail: service@alpatronics.de

E-Mail: info@alpatronics.de
Web: www.alpatronics.de